

Design acc. : API 602 .
Face to face : EN 558-1 .
Flange ends : DIN EN1092-1 .
Test and inspection acc. : DIN EN12266 .
Body : C22.8 / 1.4301

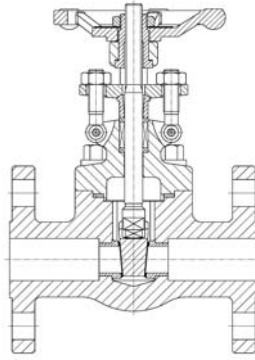

FIG : 033

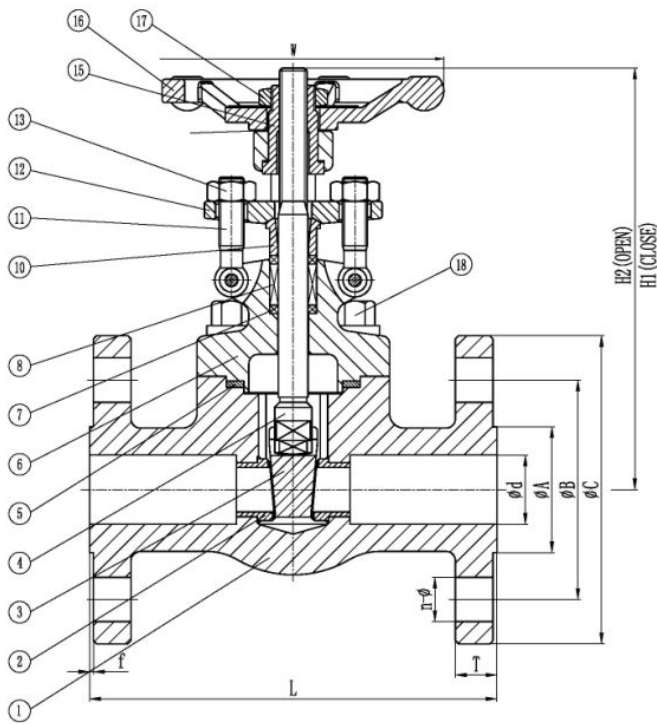

FIG.	Class	Material	Range
145.033	40	C22.8	DN15-DN50
225.033	40	1.4301	DN15-DN50

Design acc. : API 602 .
Face to face : EN 558-1.
Flange ends : DIN EN1092-1 .
Test and inspection acc. : DIN EN12266.

Material list

NO.	Part	Material	
		FIG.: 145.033	FIG.: 225.033
1	Body	C22.8	1.4301
2	Seat	1.4021	1.4301
3	Wedge	1.4021	1.4301+STL
4	Stem	1.4006	1.4301
5	Bonnet gasket	Spiral wound graphite+1.4301	Spiral wound graphite+1.4301
6	Bonnet	C22.8	1.4301
7	Packing	Flexible graphite +s.s.wire	Flexible graphite +s.s.wire
8	Packing	Flexible graphite	Flexible graphite
10	Gland	1.4021	1.4301
11	Eyebolt	G	A2
12	Gland flange	C22.8	1.4301
13	Nut	YK	A2
15	Stem nut	1.4006	1.4006
16	Handwheel	A197	A197
17	Lock nut	YK	A2
18	Bolt	G	A2

Dimension List

PN	DN	L	H1	H2	d	W	A	B	C	T	f	n-Φ
40	15	130	137	153	15	100	45	65	95	16	2	4-14
	20	150	137	153	20	100	58	75	105	18	2	4-14
	25	160	164	185	25	125	68	85	115	18	2	4-14
	32	180	195	222	32	160	78	100	140	18	2	4-18
	40	200	208	240	40	160	88	110	150	18	3	4-18
	50	230	238	279	50	180	102	125	165	20	3	4-18